

MARSDEN

USER MANUAL

M-650

M-651

M-652

M-653

Please take time to read these instructions before starting to use the scale



Contents

Introduction	3
Product Specification	3
Safety Instructions	4
Explanation of Graphic Symbols	5
Power Supply and Low Battery	6
Assembly: Indicator Bracket	7
Assembly: Handrails	8
Operation: Basic Functions	13
Operation: Advanced Functions	15
Using the Scale with a Printer	19
Using the Scale with Bluetooth	20
EMC Guidance and Manufacturer's Declaration	21
Recommended Separation Distance	23
Manufacturer's Declaration of Conformity	24

Thank you for purchasing a Marsden professional medical scale. This is a precision Class III Weighing Instrument and considerate use will result in many years of accurate weighing.

The scale has a maximum load capacity of 300kg which must not be exceeded.

Marsden's policy is one of continuous development and therefore we reserve the right to change product specification without notice.

Product Specification

Model	M-650/M-651/M-652/M-653
Accuracy Class	Class III
Capacity/Division	300kg x 100g
Weight of Scale	Approximately 28.8kg (base only)
Units of Measure	Kg
Function Keys	ON/OFF, HOLD, TARE, BMI, UNIT, PRINT, 0-9
Stabilization Time	1-2 Seconds
Operating Temperature	0 to 40°C
Power Supply	6 x AA batteries* Rechargeable battery pack 12X 1A AC Adaptor
Indicator Display	1" LCD display with 5 active digits
Dimensions (w x d x h)	1150 x 800 x 66mm (base only)
Options	Indicator stand (M-651 only) 2 x handrails and cross bar (M-652 only) 1 x handrail (M-653 only)

*Cannot be powered by six AA batteries as standard. Please contact Marsden for further information.

Safety Instructions

Before putting the device into use, please read with care the information given in this user manual, which contains important instructions for proper installation, use and maintenance of the device.

Marsden/the manufacturer shall not be liable for damages arising from failure to heed the following instructions:

- When using electrical components under increased safety requirements, always comply with appropriate regulations.
- Inappropriate installation/use will render the warranty null and void.
- Ensure the voltage marked on the power supply unit matches your mains supply.
- This device is designed for use indoors.
- Observe the permissible ambient temperatures for use.
- The device meets the requirements for electromagnetic capability. Do not exceed the maximum values specified in the applicable standards.
- Batteries should be kept away from small children. If swallowed, promptly seek medical assistance.

If you have any problems, contact Marsden/your local dealer/your service partner.

Cleaning

- We recommend using alcohol-based wipes or similar when cleaning the scale.
- Please do not use large amounts of water when cleaning the scale as this will cause damage to the inner electrics. Please refrain from using corrosive liquids or high pressure washers.
- Always disconnect the scale from the mains power supply before cleaning.

Maintenance

- The scale does not require any routine maintenance. However, we recommend checking the scale's accuracy at regular intervals. For information regarding Marsden service contracts call 01709 364296.
- If any inaccuracies occur, please contact your local dealer or service partner.

Disposing of the Scale

- This product should not be treated as regular household waste, but should be handed in to an electrical/electronic equipment recycling centre.
- You can obtain further details from your local council, your municipal waste disposal company or from where you purchased the product.

Explanation of Graphic Symbols

SN-21300100



Designation of the serial number of every device.

(Number as an example)

“Please note the accompanying documents” or “Observe operating instructions”

Identification of manufacturer of medical product including address.

Charder Electronic Co. Ltd
No.103 Guozhong Rd, Dali Dist,
Taichung City 412, Taiwan (R.O.C)



“Electro-medical appliance” with attachment of type B.



Dispose of old appliances separately from your household waste.
This product must be disposed of at a communal collection point.



Carefully read this operation manual before setup and commissioning, even if you are already familiar with Marsden scales.

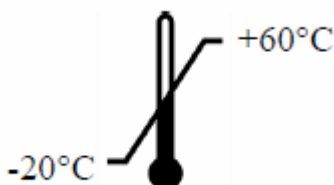

Transport and storage temperature limit indicating the upper and lower limit (transport and storage temperature on packaging).

Power Supply & Low Battery

The indicator uses a rechargeable battery pack, or can be powered from the mains via the AC adaptor.

Make sure the battery pack is installed in the battery box of the indicator. Alternatively, plug the AC adaptor (12V 1A) into the port on the side of the scale.



Installing & Replacing the Battery Pack

1. Take out the battery housing, and reset the rechargeable battery.
2. The rechargeable battery pack will slide into, or out of, the housing.

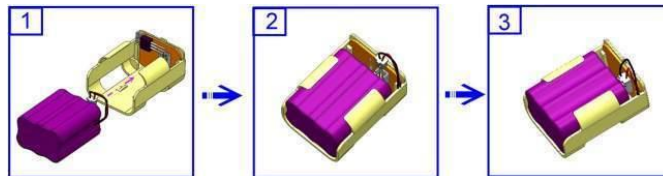

3. Check that the housing pin is connected to the right point inside the indicator.

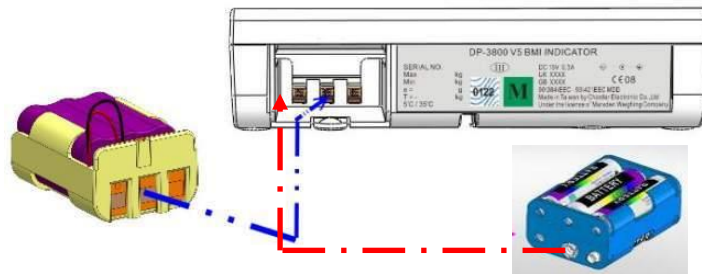





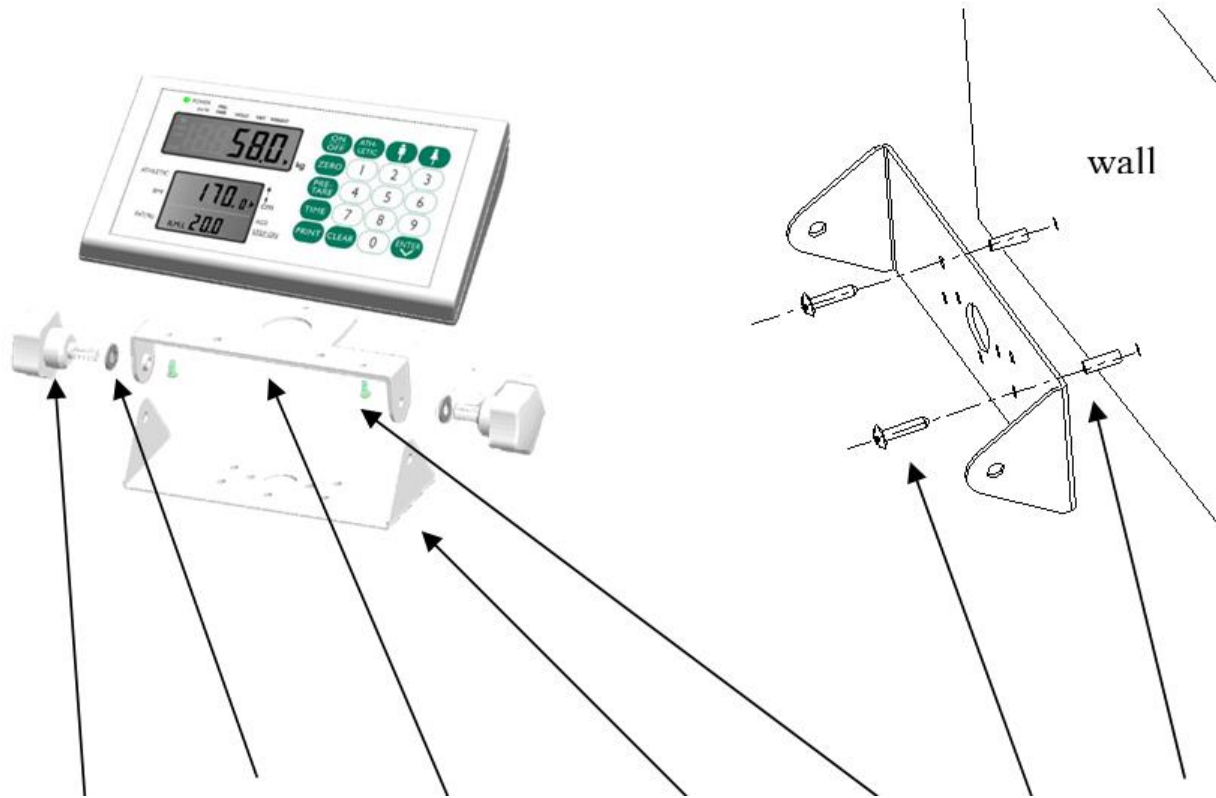

Optional battery holder (to fit AA batteries – contact Marsden or your dealer)

4. Place the housing back inside the indicator, and close the battery housing cover.

Assembly: Indicator Bracket



						
Adjustable feet	Spacer	Fixed plate (top)	Fixed plate (bottom)	Tapping Screw	Screw	Plastic anchor
2	2	1	1	2	2	2

Assembly: Handrails (M-652/M-653 Only)

Left Handrail

NO.	Item	Drawing	Qty.
1.	Handrail bar without screw hole	SS-8300A	1
2.	Fixing plate	SS-8311	4
3.	Socket button head cap screw	M6-21	10
4.	Pole	AM-8173	2
5.	Socket button head cap screw nut	ø8-M6*33	12
6.	Socket key		2

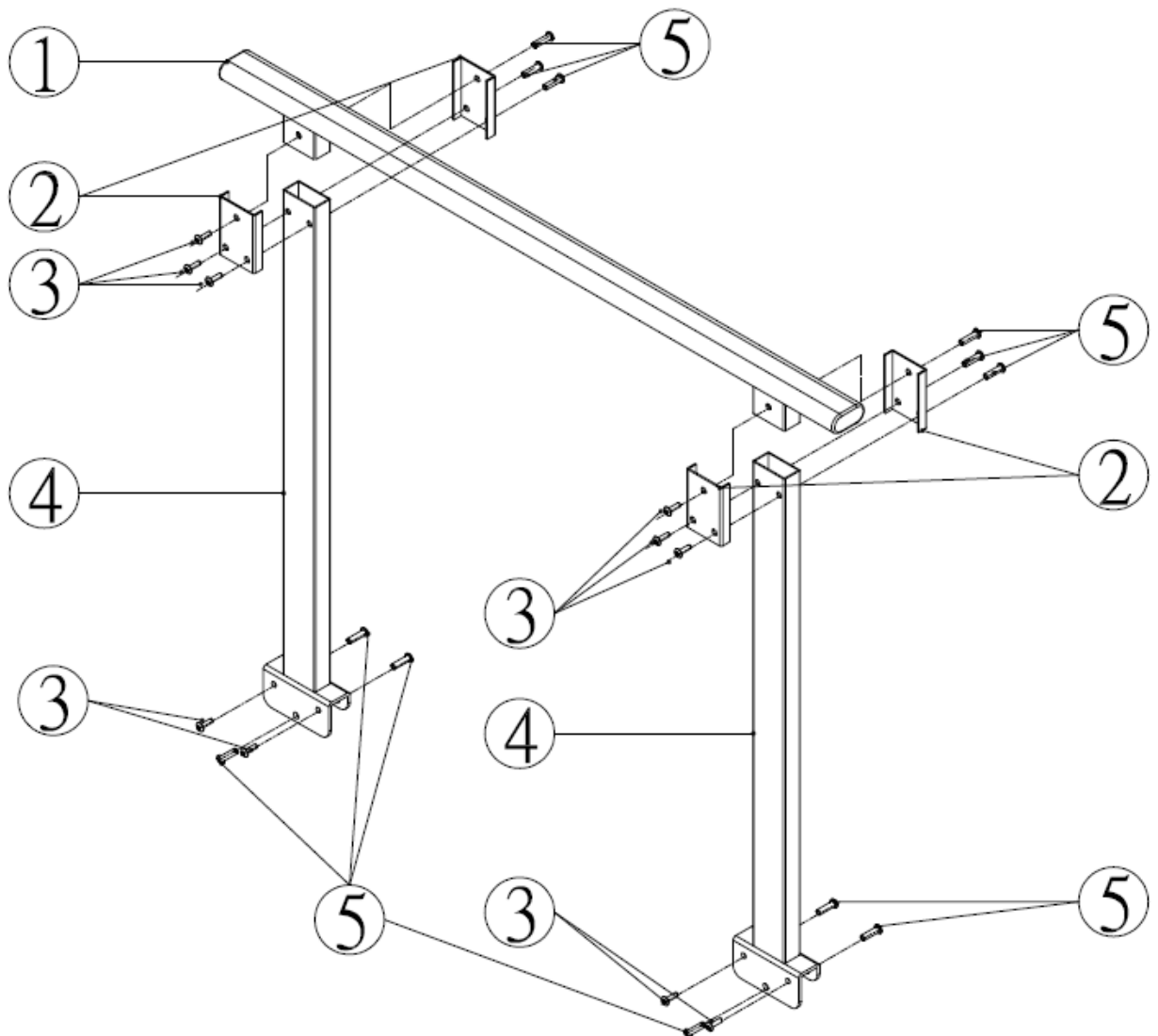

Right Handrail

NO.	Item	Drawing	Qty.
1.	Handrail bar	SS-8300B	1
2.	Fixing plate	SS-8311	4
3.	Socket button head cap screw	M6-21	10
4.	Pole	AM-8173	1
5.	Socket button head cap screw nut	ø8-M6*33	12
6.	Screw for display set	M4*6	2
7.	Screw nut for printer bracket	M5-0.8-JB	2
8.	Plastic screw	M5-0.8*8	2
9.	Pole with wiring duct	AM-8173A	1
10.	End cap	SW-8068	2
11.	Screw Nut	M8*1.25*8	1
12.	Bearing	SF-1F-08075	2
13.	Bracket	SS-8303A	1
14.	Cable organiser	TC-2WE 100CM	
15.	Socket key		2

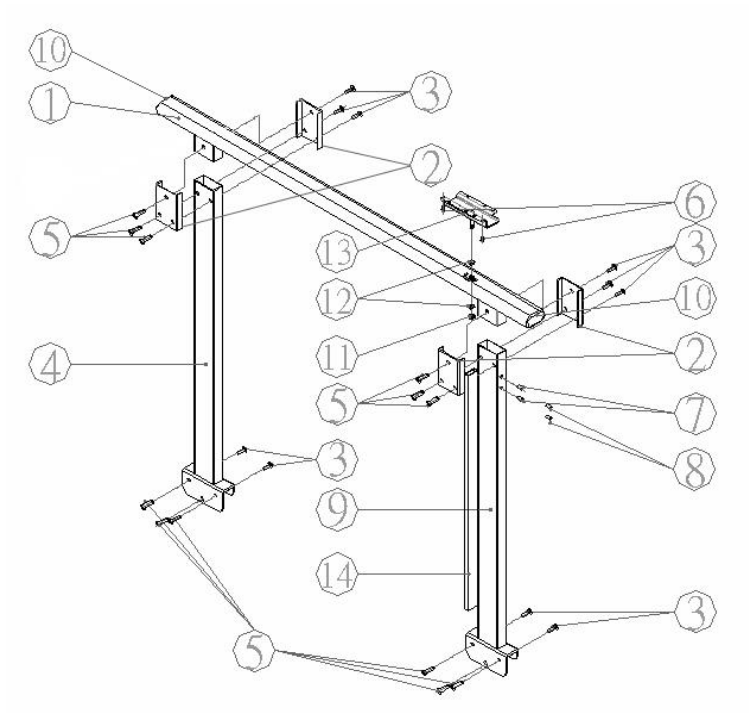

Step 1.

Fix no.2 (fixing plate) on no.9 (pole with wiring duct) with no.3 (socket screw) and no.5 (screw nut).

Fix no.9 (pole with wiring duct) on platform by using no.3 and no.5.

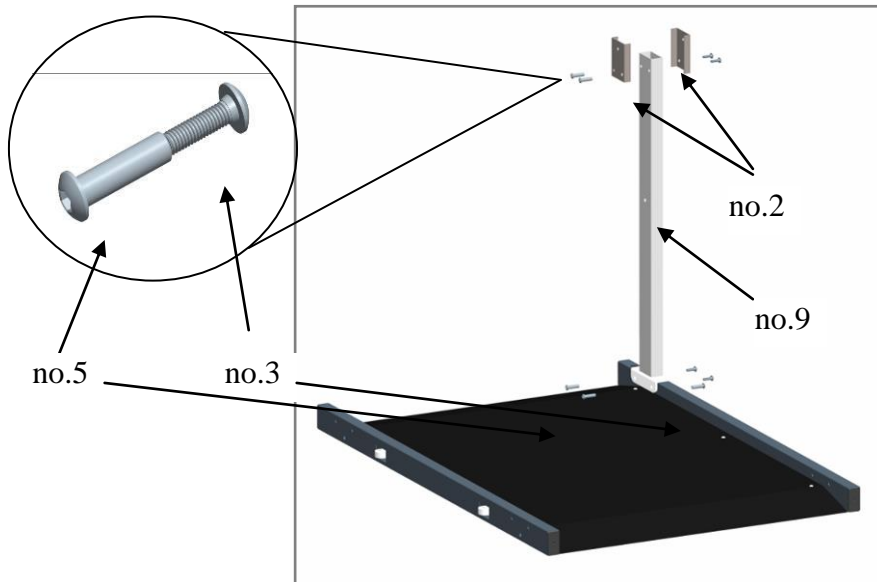

Step 2.

Assemble pole on platform, as per Step 1.

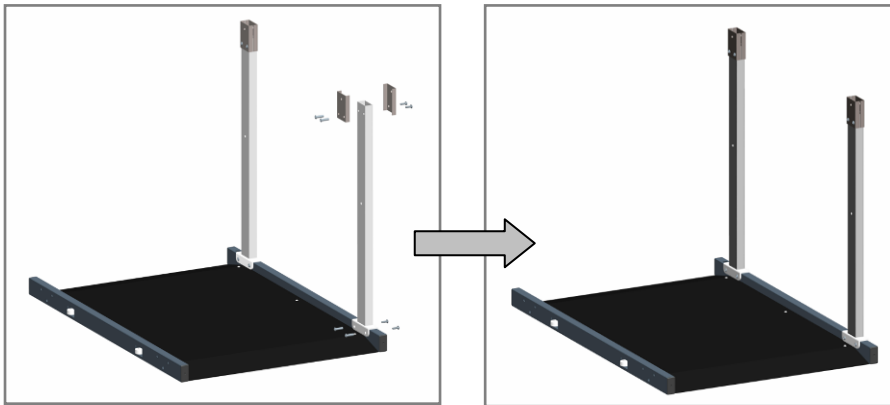

Step 3.

Attach no.1 (handrail bar) to poles, using no.3 (socket screw) and no.5 (screw nut).

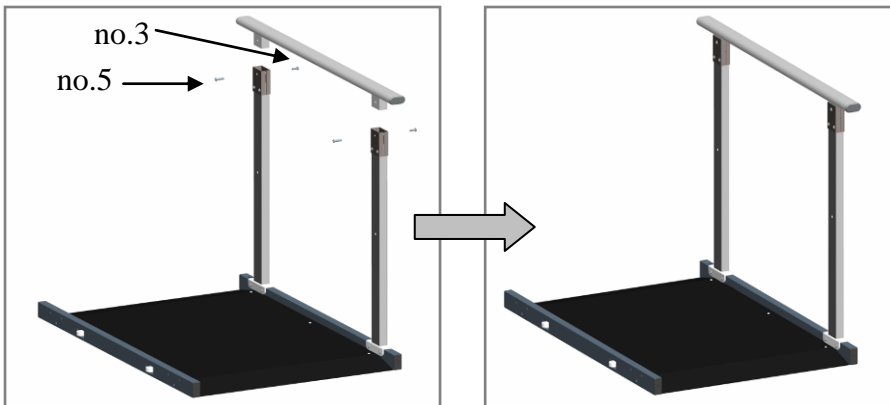

Step 4.

For M-652, repeat Steps 1-3.

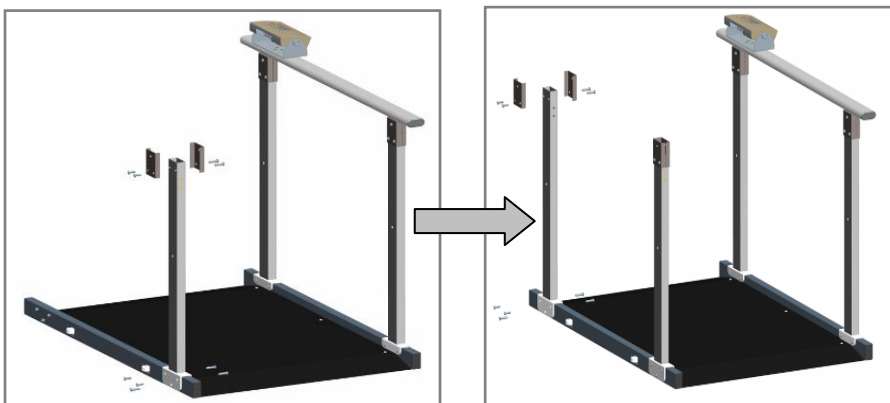

Step 5.

With handrails assembled, attach no.13 (bracket for indicator) using no.6 (screw)

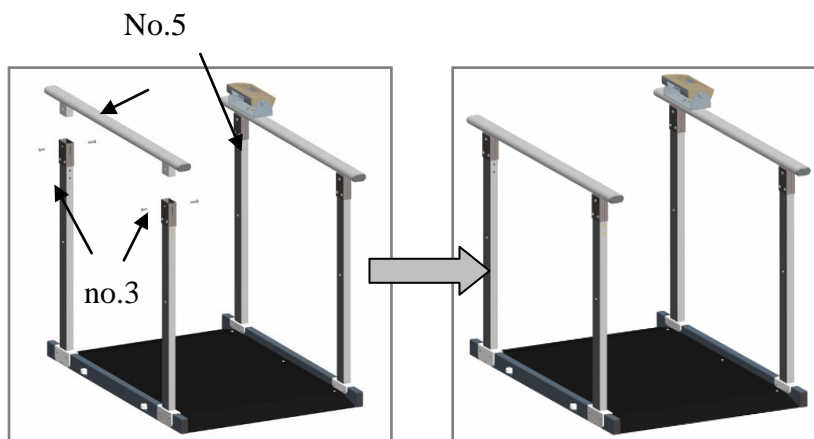

Step 6.

For M-652, assemble cross bar (SS-8444) with two screws (M8-1.25P*45).

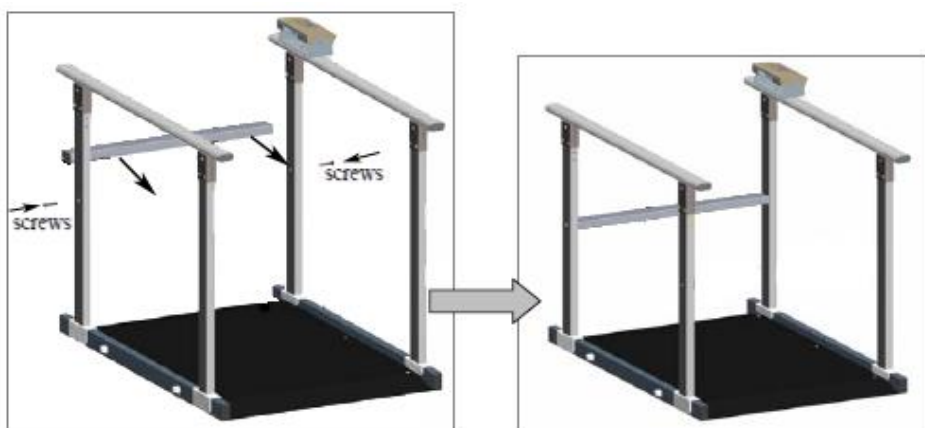

Operation: Basic Functions

Switching on the Scale

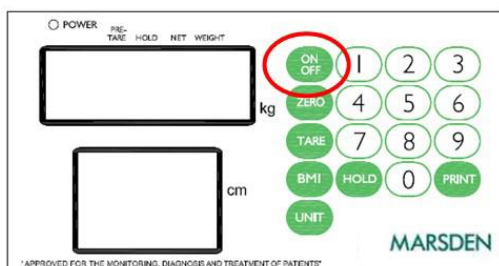

Press the ON/OFF button firmly.

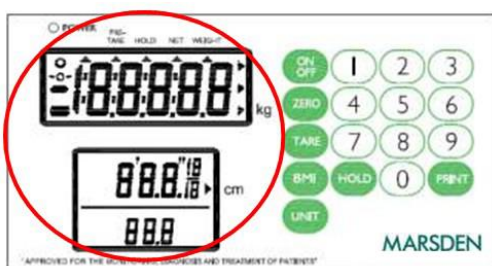

The scale will first test all of the display segments.

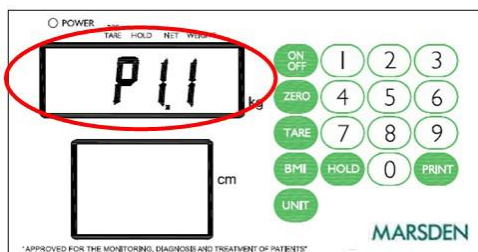

The scale will now show its current software version number.

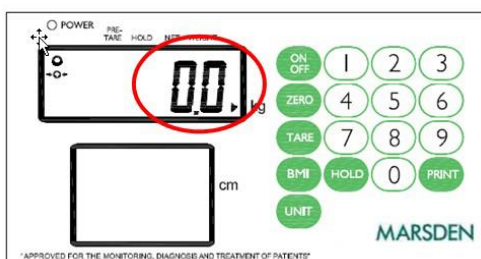

The scale will now go into weighing mode and should show 0.0 on the display.

Switching off the Scale

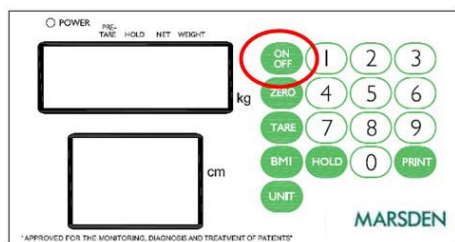

Press the ON/OFF button when the scale is turned on. The scale will now power down.

Setting the Scale to Zero

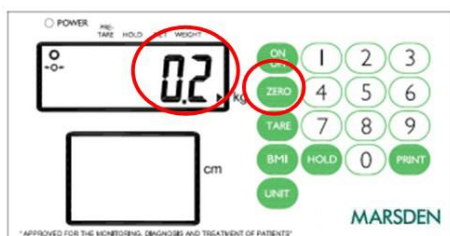

If for any reason the scale shows a reading other than 0.0 it can be reset to zero.

Press the ZERO key once.

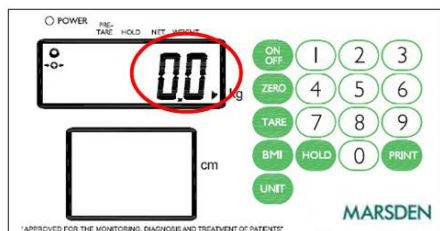

The scale will return to 0.0.

Operation: Advanced Functions

Hold Function

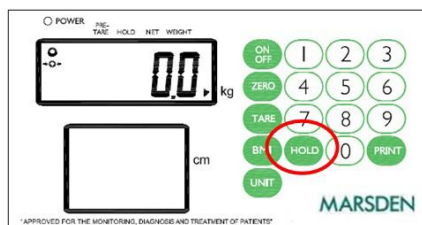

Press the HOLD button once.

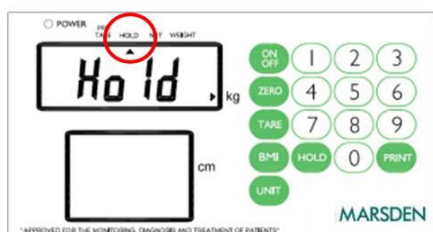

Allow the patient to stand on/be wheeled onto the scale.

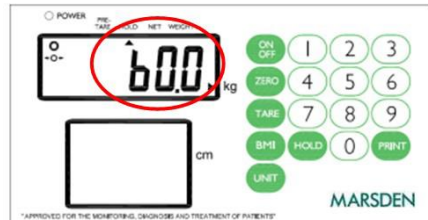

After a few seconds the scale will lock on the person's weight. When the patient leaves the scale, the weight will remain on the display.

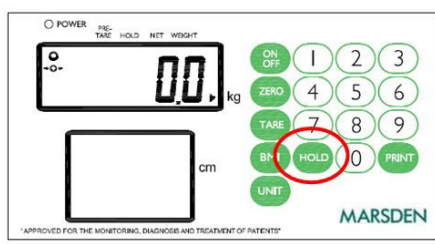

Press HOLD again to disable the Hold function and return the scale to 0.0.

Body Mass Index (BMI) Function

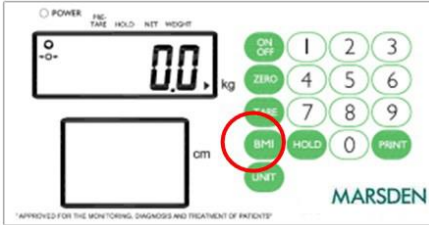

In normal mode, press the BMI key to enter BMI mode.



The display will show the last height entered and the extreme left digit will flash. Enter the height by using the numeric keys. Press the ZERO key to confirm the height. (NB: There will always be an active flashing digit in the height display, unless HOLD is pressed).

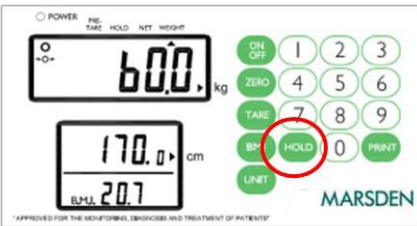

Weigh the patient as normal. The display will show the weight, height and BMI value. At this time, the weight and height can be freely changed, and the BMI value will be automatically calculated according to the changed weight and height.

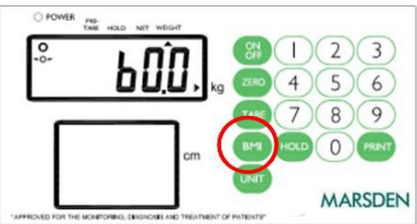

Press the BMI key to return to normal weighing mode.

Tare and Pre-set Tare Functions

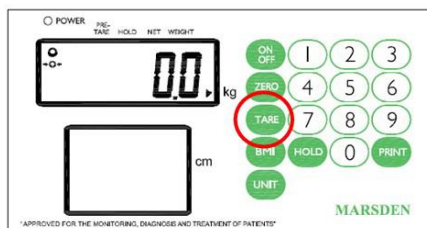

Press the TARE key for three seconds to enter Pre-set Tare setting mode.

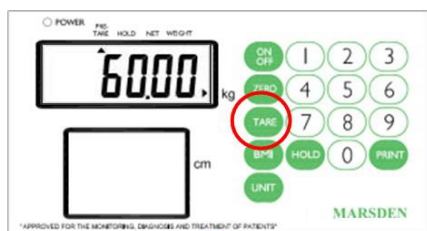

The display will show the last pre-set tare entered and the extreme left digit will flash.

Enter the pre-set tare value by using the numeric keys, then press the TARE key again to confirm the value.



Press the ZERO key to return to the normal mode.

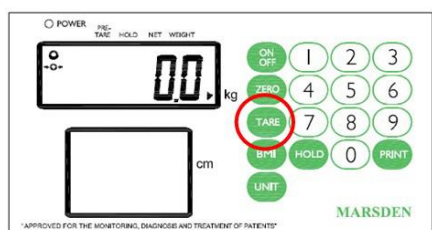

To use the Tare function, add the item you wish to tare off to the scale, and press the TARE key. The display will show zero, and then a minus number when the item is removed from the scale.

Setting the Date

Press the HOLD key for three seconds to access the time setting mode. The time period digit that is flashing can be changed by entering the appropriate number from the numeric key pad. The time period to be edited is selected by pressing the HOLD key.

E.g. To input 25 December 2008, 8:00 a.m.:



Enter the year. Press HOLD to confirm and access the date editing field.

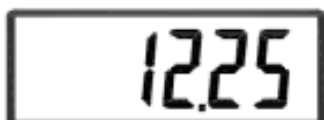

Enter the date. E.g. "12.25" for December 25th. Press HOLD to confirm and access the time clock editing field.



Enter the time (24 hour clock only).

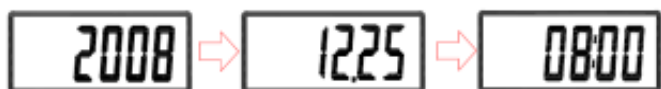

Press HOLD and the display shows:
YYYY→MM.DD→HH:SS



Press HOLD to return to normal weighing mode.

Using the Scale with a Printer

An optional Marsden external printer (model TP-2100) is available for all models. When the printer is fitted, the patient's weight, height, and BMI result can be printed.

Once the person has been weighed and their BMI calculated, simply press the PRINT key to produce the following ticket:

GROSS WEIGHT	60.00kg
TARE WEIGHT	30.00kg
NET WEIGHT	30.00kg
PATIENT HEIGHT	100.0cm
PATIENT B.M.I	37.5
29/12/2008 17:00	

Assembling: TP-2100 Thermal Printer



Plug the cable to the printer, and then connect its 9D connector to the indicator.

Using the Scale with Bluetooth

If your scale has Bluetooth connectivity, the universal Bluetooth symbol will be on the main indicator display.

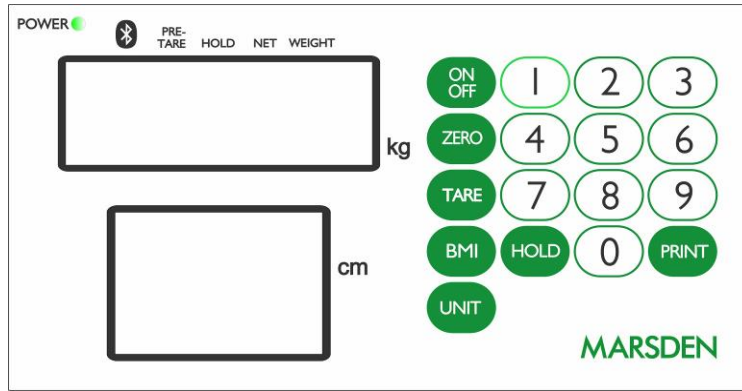

Bluetooth Connection

A OFF

Long press the ZERO key for three seconds to enter the Setting mode and then display the A-OFF menu.

bluEt

Press the TARE key twice, and then press HOLD once to enter the Bluetooth setting mode.

On ← → OFF

Using the HOLD key, select "ON" (enable) or "OFF" (disable). Press the TARE key to confirm the setting.

Note: Disabling the Bluetooth function when not in use will reduce battery power consumption.

bluEt

Display the "bluEt" menu. Press the TARE key once.

End

Press the HOLD key to return to normal mode.

Search for the scale in your computer or device's Bluetooth settings (procedure may vary depending on device or system)

The scale will appear on the Bluetooth device list as "**MARSDEN BT**".

Connect your device to "MARSDEN BT", and the scale is ready to transmit data wirelessly via Bluetooth.

EMC Guidance and Manufacturer's Declaration

Guidance and manufacturer's declaration – electromagnetic emissions.

The M-650/M-651/M-652/M-653 is intended for use in the electromagnetic environment specified below. The customer or user of this scale should assure that it is used in such environment.

Emission Test	Compliance	Electromagnetic environment-guidance
RF emissions CISPR 11	Group 1	This scale uses RF energy only for its internal function. Therefore, its RF emissions are very low and not likely to cause any interference in nearby electronic equipment.
RF emissions CISPR 11	Class B	This scale is suitable for use in all establishments, including domestic establishments and those directly connected to the public low-voltage power supply network that supplies buildings used for domestic purposes.
Harmonic emissions IEC 61000-3-2	Class A	
Voltage fluctuations/flicker emissions IEC 61000-3-3	Compliance	

Guidance and manufacturer's declaration – electromagnetic immunity.

The M-650/M-651/M-652/M-653 is intended for use in the electromagnetic environment specified below. The customer of the user of this scale should assure that it is used in such an environment.

Immunity Test	IEC 60601 Test Level	Compliance Level	Electromagnetic Environment Guidance
Electrostatic discharge (ESD) IEC 61000-4-2	± 6 kV contact ± 8 kV air	± 6 kV contact ± 8 kV air	Floors should be wood, cement or ceramic tile. If floors are covered with synthetic material, the relative humidity should be at least 30%.
Electrical fast transient/burst IEC 61000-4-4	± 2 kV for power supply lines +1kV for input/output lines	± 2 kV for power supply lines not applicable	Mains power quality should be that of a typical commercial or hospital environment.
Surge IEC 61000-4-5	± 1 kV line(s) to line(s) ± 2 kV line(s) to earth	± 1 kV differential mode not applicable	Mains power quality should be that of a typical commercial or hospital environment.
Voltage Dips, short interruptions and voltage variations on power supply input lines IEC-6100-4-11	<5% UT (>95% dip in UT) for 0.5 cycle 40% UT (60% dip in UT) for 5 cycles 70% UT (30% dip in UT) for 25 cycles <5% UT (>95% dip in UT) for	<5% UT (95% dip in UT) for 0.5 cycle 40% UT (60% dip in UT) for 5 cycles 70% UT (30% dip in UT) for 25 cycles <5% UT (>95% dip in UT) for	Mains power quality should be that of a typical commercial or hospital environment. If the user of this scale requires continued operation during power mains interruptions, it is

	5s	5s	recommended that this scale is powered from an uninterruptable power supply or a battery.
Power frequency (50/60 Hz) magnetic field IEC 61000-4-8	3 A/m	3 A/m	The scale's power frequency magnetic fields should be at levels characteristic of a typical location in a typical commercial or hospital environment.
Note UT is the A.C mains voltage prior to application of the test level.			

Guidance and manufacturer's declaration – electromagnetic immunity.

This scale is intended for use in the electromagnetic environment specified below. The customer of the user of the scale should assure that it is used in such an environment.

Immunity Test	IEC 60601 test level	Compliance level	Electromagnetic environment-guidance
Conducted RF IEC61000-4-6	3 Vrms 150 KHz to 80 MHz	3 Vrms	<p>Portable and mobile RF communications equipment should be used no closer to any part of the scale including cables, than the recommended separation distance calculated from the equation applicable to the frequency of the transmitter.</p> <p>Recommended separation distance: $d = 1,2 \sqrt{P}$ $d = 1,2 \sqrt{P}$ 80MHz to 800 MHz $d = 2,3 \sqrt{P}$ 800MHz to 2,5 GHz</p> <p>Where P is the maximum output power rating of the transmitter in watts (w) according to the transmitter manufacturer and d is the recommended separation distance in meters (m). Field strengths from fixed RF transmitters, as determined by an electromagnetic site survey, should be less than the compliance level in each frequency range.</p> <p>Interference may occur in the vicinity of equipment marked</p>
Radiated RF IEC 61000-4-3	3 V/m 80MHz to 2,5 GHz	3 V/m	

			with the following symbol: 
NOTE1 At 80 MHz and 800 MHz, the higher frequency range applies. NOTE2 These guidelines may not apply in all situations. Electromagnetic propagation is affected by absorption and reflection from structures, objects and people.			
<p>A) Field strengths from fixed transmitters, such as base stations for radio (cellular/cordless) telephones and land mobile radios, amateur radio, AM and FM radio broadcast and TV broadcast cannot be predicted theoretically with accuracy. To assess the electromagnetic environment due to fixed RF transmitters, an electromagnetic site survey should be considered. If the measured field strength in the location in which the scale is used exceeds the application RF compliance level above, the scale should be observed to verify normal operation. If abnormal performance is observed, additional measures may be necessary, such as re-orienting or relocating the scale.</p> <p>B) Over the frequency range 150 kHz to 80 MHz, field strengths should be less than 3 V/m.</p>			

Recommended separation distance between portable and mobile RF communications equipment and the M-650/M-651/M-652/M-653.

This scale is intended for use in an electromagnetic environment in which radiated RF disturbances are controlled. The customer or the user of the scale can help prevent electromagnetic interference by maintaining a minimum distance between portable and mobile RF communications equipment (transmitters) and the scale as recommended below, according to the maximum output power of the communications equipment.

Rated maximum output power of transmitter	Separation distance according to frequency if transmitter m		
	150 kHz to 80 MHz	80 MHz to 800 MHz	800 MHz to 2,5 GHz
W	$d = 1,2\sqrt{P}$	$d = 1,2\sqrt{P}$	$d = 2,3\sqrt{P}$
0.01	0.12	0.12	0.23
0.1	0.38	0.38	0.73
1	1.2	1.2	2.3
10	3.8	3.8	7.3
100	12	12	23

For transmitters rated at a maximum output power not listed above, the recommended separation distance *d* in meters (m) can be estimated using the equation applicable to the frequency of the transmitter, where *p* is the maximum output rating of the transmitter in watts (w) according to the transmitter manufacturer.

NOTE1) At 80 MHz and 800 MHz, the separation distance for the high frequency range applies.
NOTE2) These guidelines may not apply in all situations. Electromagnetic propagation is affected by absorption and reflection from structures, objects and people.

Manufacturer's Declaration of Conformity

	2014/31/EU Non-automatic Weighing Instruments Directive
---	---

Manufactured by:



Charder Electronic Co., Ltd.
No.103, Guozhong Rd., Dali Dist.,
Taichung City 412, Taiwan (R.O.C.)



Accuracy Assured

Tel: 01709 364296 / 0800 169 2775

Fax: 01709 364293

E-mail: sales@marsdengroup.co.uk

Manufacturing and Distribution:

Unit 7, Centurion Business Park,

Coggin Mill Way,

Rotherham,

S60 1FB

Head Office:

Unit 1, Genesis Business Park,

Sheffield Road,

Rotherham

S60 1DX

www.marsden-weighing.co.uk